



Application Note 411

Title: **RFID Made Easy**

Product Family: **RFID**

Part Number: EM RFID Products

Keywords: RFID techniques, RFID Principles, Antenna Design, Theory, System Design

Date: 25 September 2002

TABLE OF CONTENT

- 1 Introduction 2
 - 1.1 EM Microelectronic transponder systems 2
 - 1.2 Future trends in transponder systems 3
 - 1.3 Frequency spectrum 3
- 2 System principles 5
 - 2.1 System setup 5
 - 2.2 Electromagnetic field theory 6
 - 2.3 Magnetic field and inductivity 7
 - 2.4 Transformer principles and magnetic coupling 7
 - 2.5 Quality factor, phase shift and bandwidth 8
- 3 Antenna design 10
 - 3.1 General resonant circuit parameters 10
 - 3.2 Antenna parameters 11
 - 3.3 Antenna fine tuning 12
- 4 Data Coding/Encoding 13
 - 4.1 Non-return to Zero Modulation (NRZ) 13
 - 4.2 Return to Zero Modulation (RZ) 13
 - 4.3 Manchester Coding 14
 - 4.3.1 Differential Manchester Coding 14
 - 4.4 Biphase Coding 15
 - 4.4.1 Differential Biphase Coding 15
 - 4.5 Miller Coding 15
 - 4.6 Phase Shift Keying 16
- 5 Bibliography 17
- 6 Glossary 17
- 7 Appendix 18
 - 7.1 Institutes 18
 - 7.2 Trade fairs: 18
 - 7.3 Copper Wire List 18

1 Introduction

The recent years showed an immense increase in quantity of Radio Frequency Identification (RFID) semiconductors such as transponders and transceiver circuits. Many system house companies with main forces in software or hardware design become more interested in that new technology. The high integration of RFID circuits allows a relatively easy implementation into any customer specific application. Nevertheless, you will need some basic knowledge of RF theory to achieve the maximum performance in your system.

The aim of this RFID Design Guide is to give you the relevant guidelines for your design using standard integrated circuits.

1.1 EM Microelectronic transponder systems

The Contactless Identification activity began in 1989 and today comprises some 50 products in production, which are used in a huge quantity of application like Access Control, Animal Identification, Car Immobilisation, Laundry Tagging, Logistic, Sports Performance etc [Bibliography B4].



Figure 1: Transponders packed as disks



Figure 2: Transponders in keys



Figure 3: Transponder packet in a wrist watch

The know-how of EM Microelectronic in RFIDs lays in its Ultra Low Power Technology, allowing Analog & Logical Structures, ROM and EEPROM Memories to be combined on the same chip [B6]. Thanks to this know-how acquired over the years, EM Microelectronic has been able to develop circuits for all ranges of frequency, Read Only circuits as well as Read / Write, ASIC or Standard Products.

The Standard Products are shown below:

Transponder Circuits
<p>EM4100</p> <ul style="list-style-type: none"> • Operating frequency 100 - 150 kHz • 64 bit memory array laser programmed • Manchester, Bi-Phase or PSK modulation • On chip resonance capacitor 75pF • Optional Data Rate
<p>EM4006</p> <ul style="list-style-type: none"> • Operating frequency 13.56MHz • 64+16 CRC bit laser memory array • Miller encoding • 94.5 pF ± 2% on chip Resonant Capacitor • Optional Data Rate
<p>EM4022</p> <ul style="list-style-type: none"> • Supertag™ anticollision protocol • Frequency independent • 64 bit laser memory array



EM4069

- Operating frequency 100 - 150 kHz
- 128 bit EEPROM
- OTP feature convert EEPROM words in Read Only
- 64 bit fixed code memory array laser programmed
- Data encoding : Manchester or Bi-phase
- Transmission reader to chip : 65% AM modulation
- Data rate : 2 or 4 Kbaud
- 75pF on chip Resonance Capacitor

EM4005

- Operating frequency 100 - 150 kHz
- 128 bit memory array laser programmed
- Bit coding according to ISO FDX-B
- On chip resonance capacitor 75pF

EM4150

- Operating frequency 100 - 150 kHz
- 1 KBit of EEPROM
- 32 bit Device Serial Number (Laser ROM)
- 32 bit Device Identification (Laser ROM)
- User defined Password
- User defined Read Memory Area at Power On
- User defined Write Inhibited Memory Area
- User defined Read Protected Memory Area
- 170 pF \pm 2% on chip Resonant Capacitor
- On chip Rectifier and Voltage Limiter

Transceiver Circuit

EM4095

- PLL which adapts carrier frequency to antenna resonant frequency
- No external quartz required
- 100kHz to 150kHz carrier frequency range
- Data transmission performed by Amplitude Modulation
- Multiple transponder protocol compatibility (EM400X, EM4050, EM4069 etc.)
- Sleep mode 1 μ A
- Antenna short circuit detection

1.2 Future trends in transponder systems

What will bring us the future in RFID? There are three main topics, where a constant improvement is taking place:

Design and Technology

- Manufacturing methods
- Frequency spectrum allocation

The low power design is a master key to low price RFID chip production. With smaller structures the surface of the chip and the power can be reduced. Smaller chip surfaces will bring new assembly technologies, such as flip-chip technology. Working with higher frequencies such as 13.56MHz or higher will reduce the number of turns of the antenna, as well as the resonance capacity. Furthermore the data transmission rate can be increased. With higher frequencies, longer reading ranges occur. Thus, Multitag applications will become more important. Tradefares like Scantech are always presenting trendsetting products [Appendix A5].

EM Microelectronic will be able to profit from its 10 years experience in RFID chip-design and manufacturing.

1.3 Frequency spectrum

RFID systems are regarded as radio emitting devices and therefore the international and domestic radio regulations are relevant. This means that the frequency selection is restricted to a number of fixed frequency bands. The most common frequencies used are 0... 135kHz, 400kHz, 6.78MHz, 13.56MHz, 27.125MHz, 40.68MHz, 433.29MHz, 869MHz, 915MHz, 2.45GHz, 5.8GHz and 24.125GHz [B3]. Frequencies are divided in the following ranges:

Freq. Range [Hz]	Wavelength λ [m]	Name	Abbr.
3 ... 300	$10^8 \dots 10^6$	extremely low freq.	ELF
300 ... 3k	$10^6 \dots 10^5$	ultra low frequency	ULF
3k ... 30k	$10^5 \dots 10^4$	very low frequency	VLF
30k ... 300k	$10^4 \dots 10^3$	low frequency	LF
300k ... 3M	$10^3 \dots 10^2$	medium frequency	MF
3M ... 30M	$10^2 \dots 10^1$	high frequency	HF
30M ... 300M	$10^1 \dots 10^0$	very high frequency	VHF
300M ... 3G	$10^0 \dots 10^{-1}$	ultra high frequency	UHF
3G ... 30G	$10^{-1} \dots 10^{-2}$	super high frequency	SHF
30G ... 3000G	$10^{-2} \dots 10^{-4}$	extremely high freq.	EHF

Table 1: EM Microelectronic Standard Products

Table 2: Normalised Frequency Ranges [B1]



In the US the 420MHz... 460MHz band was not favoured but therefore the 315MHz and 902MHz... 928MHz bands have been allocated. Due to the restricted use of this band for GSM mobile phones European regulations offered an appropriate frequency at 869MHz. The International Telecommunications Union (ITU), a Suborganisation of the United Nation Organisation situated in Geneva aims to harmonise these frequencies world-wide [A1].

The maximum power allowed in the EU is $0.5 W_{ERP}$. A tag at $0.5 W_{ERP}$ at UHF has a working range of about 30cm. $0.5 W_{ERP}$ is about 50'000 times below health reference level.

Relevant regulations concerning RFID system are the ETSI standards EN 300220, EN 300330, EN 300440 and the EMC regulation EN 300683 [A3]. Based on those regulations CEPT introduced ERC 70-03 in 1997, which is now relevant for national regulations.

Frequency	125 kHz	13.56 MHz
Data rate	500 bit/s... 8 kbit/s	500 bit/s... 106 kbit/s
Coil windings	40... 300	1... 10
Reading distance	dependent of reader design	dependent of reader design
Anticollision	< 10 tags/s	< 50 tags/s
Security	independent of frequency	independent of frequency
Regulations	EN 300330 ¹⁾	EN 300330 ¹⁾

¹⁾ see also FCC PART 15: RADIO FREQUENCY DEVICES [A4].

Table 3: RFID system comparison

2 System principles

The following chapter is an introduction to the electromagnetic field theory that is used to design your RFID application. Most examples are calculated with a working frequency of $f = 125\text{kHz}$. Of course the theory covers also higher frequencies, but parasitic effects will be more delicate.

2.1 System setup

A basic RFID system setup consists of three parts:

- a single or multiple identification labels (transponders or tags),
- a transceiver interface, to communicate between the uC and the transponder,

a data processing unit, such as a microcontroller.

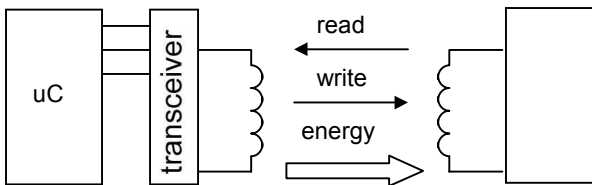

Figure 4: Basic RFID system setup

The reader (transceiver) is usually a fix mounted system, whereas the transponder is the moving part, e.g. in access control, or animal tagging. The reader and the transponder are working as a wireless, magnetic coupled communication system, each with a resonance circuit tuned to the frequency as close as possible. The reader provides energy to the transponder by an electromagnetic field. By modulating this field, the reader can transmit (write) data to the transponder. The transponder will power up and return its on-chip data to the reader.

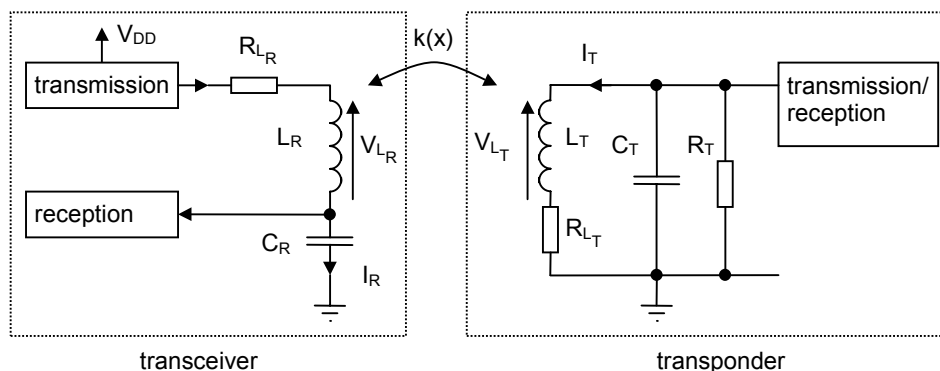

Figure 5: RFID system frontend [B4]

The above figure shows the more detailed analog frontends of the transceiver and the transponder. Both circuits have to be tuned on a resonance frequency e.g. $f = 125\text{kHz}$. The reader is working in series resonance, the transponder with a parallel resonance circuit.

2.2 Electromagnetic field theory

Today, most common transponders are magnetically coupled devices. As we know, a magnetic field can be divided in a near (proximity) field and a far field. Inductive coupling is only possible in the near field. The communication range

$$r_x \leq \frac{\lambda}{2\pi} \quad [m] \quad (1)$$

represents the physical limit of the working range, while the wavelength is

$$\lambda = \frac{c}{f} \quad [m] \quad (2)$$

and $c=299.79\text{km/s}$ and f the magnetic field frequency.

To set up a proximity electromagnetic field (EF) usually a circular loop antenna wound of a numerous turns of fine wire is used. The reader antenna emits an EF of the strength $H(x)$.

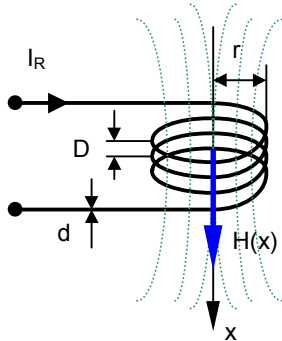

Figure 6: A short cylindric coil

$$H_R(x) = \frac{I_R N_R r_R^2}{2(r_R^2 + x^2)^{3/2}} \quad \left[\frac{A}{m}\right] \quad (3)$$

Now we aim to optimise the reader antenna to a given reading range. We can see that the EF strength is maximised when the following setup is given:

$$r_R \cong \sqrt{2} \cdot x \quad [m] \quad (4)$$

In other words, r_R has to be approximately 40% bigger than the desired reading range x . This effect can

mathematically be shown by deriving (3) with respect to the radius r_R .

The next figure shows where the maximum EF strength H as a function of the loop antenna radius r_R with a fixed distance x to the transponder antenna can be found.

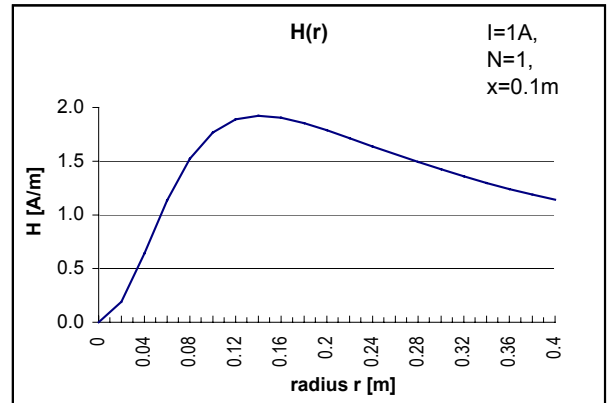

Figure 7: The magnetic field strength $H(r)$

If you are designing the antenna of the reader, consider that you match the desired minimum H_{\min} of the transponder.

The next illustration shows the EF strength for different loop antenna diameters as a function of the reading distance x .

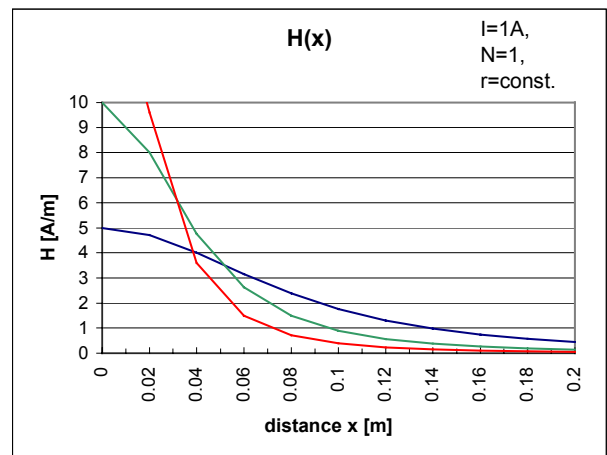

Figure 8: Normalised $H(x)$ with three different reader antenna diameters

Fig. 8 visualises the effect, that $H(x)$ is falling faster by decreasing the reader antenna radius.

2.3 Magnetic field and inductivity

This chapter describes the calculation of the inductivity L of a certain antenna. The inductivity is basically a pure issue of material and geometry.

By using Biot-Savart the flux density B is given by

$$B_R(x) = \mu \cdot H = \frac{\mu \cdot I_R N_R r_R^2}{2(r_R^2 + x^2)^{3/2}} \quad \left[\frac{Vs}{m^2} = T \right] \quad (5)$$

Knowing that the magnetic flux is

$$\Phi = \frac{L \cdot I}{N} = B \cdot A \quad [Vs] \quad (6)$$

We aim to isolate the inductivity L. For most RFID applications a circular reader coil will be used and therefore the simple formula, where the factor 1.9 in formula (7) is given by experience [B2]:

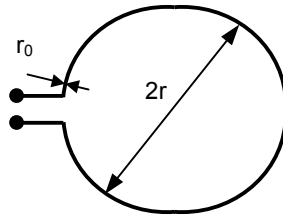

$$L = \mu_0 \cdot N^{1.9} \cdot r \cdot \ln\left(\frac{r}{r_0}\right) \quad \left[\frac{Vs}{A} = H \right] \quad (7)$$

$$\frac{r_0}{2r} \ll 0.7 \quad (8)$$

The magnetic field constant is

$$\mu_0 = 4 \cdot \pi \cdot 10^{-7} \quad \left[\frac{Vs}{Am} \right] \quad (9)$$

For RFID applications the reader antenna inductivity L is usually in the range of 350μH... 800μH. These values fit well for with transponders using flat circular or square air coils, such as credit card and access applications.

Other forms of antennas exist, such as the ferrite core antenna with a varying directional performance. Such antennas may be required in applications like immobilises, where the overall tag volume must be respected to a given distance performance in a system with fixed geometry. An appropriate formula for such coils is:

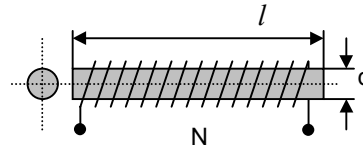

$$\frac{r_0}{2r} \ll 0.7 \quad (9)$$

Where μ_r represents the permeability of the ferromagnetic material, which is a 2'000 and more, depending on the material.

As shown above, the antenna inductivity can be evaluated with practical formulas. As they are empirical, they will only give you an approximate value, which means, that you have to measure the antenna and adjust the value.

2.4 Transformer principles and magnetic coupling

This chapter aims to calculate the coupling factor k of an RFID system. The coupling factor is a major key to a proper working RFID application.

As we saw before, RFID applications with passive transponders are used in close coupling (proximity field) mode. Therefore the transformer theory will help to calculate the necessary parameters.

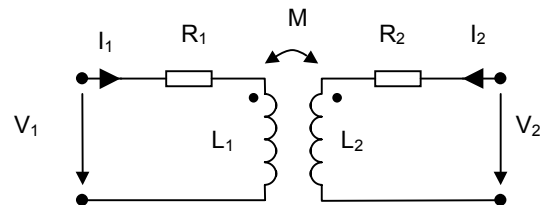

Figure 9: Transformer model

$$V_1 = I_1(R_1 + j\omega L_1) + I_2 j\omega M \quad [V] \quad (11)$$

$$V_2 = I_2(R_2 + j\omega L_2) + I_1 j\omega M \quad [V] \quad (12)$$

M is the mutual inductivity of the transformer and k represents the magnetic coupling factor.

$$M = k \sqrt{L_1 \cdot L_2} \quad [H] \quad (13)$$

We aim to determine k as only dependent of pure geometric parameters. We need further the induced voltage in a coil if entered in an EF.

$$v = N \frac{d\Phi}{dt} = -N \cdot B \cdot A \cdot \omega \cdot \sin(\omega \cdot t) \quad [V] \quad (14)$$

Combining (5), (9), (10), (11) and (12) we get the magnetic coupling factor between the reader and the transponder antennas. The angle $\theta = 0$ if both antennas are in parallel.

$$k = \frac{r_R^2 \cdot r_T^2 \cdot \cos(\theta)}{\sqrt{r_R \cdot r_T \cdot (r_R^2 + x^2)^{3/2}}} \quad [1] \quad (15)$$

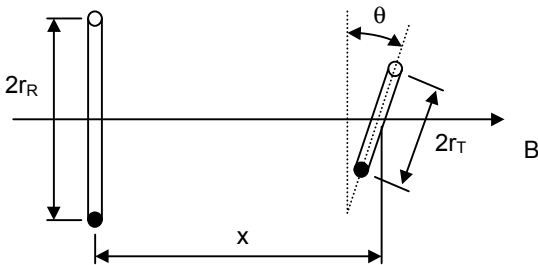

Figure 10: Parameters influencing the coupling factor k

The coupling factor is a major key to a proper working RFID application. The best system performance will be achieved with $k=1$. Thus, studying (15) closer, we can see, that k can be maximised by:

- *Minimising θ between both antennas.* If the transponder is moving and has not a fixed position like in application such as sports or animal tagging, this parameter is especially sensitive.
- *Matching the sizes of the antenna areas.* The coupling factor can be maximised if both antennas have the same area.
- *Minimising the reading-distance x .* As closer the transponder to the reader is, as better is the coupling between the antennas.

The following figure shows the coupling factor falling with rising distance x :

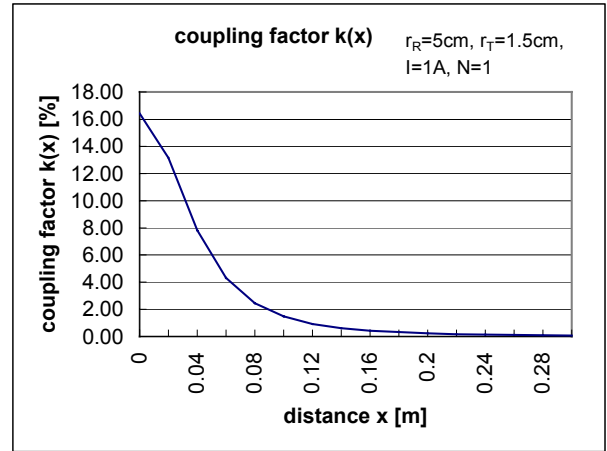

Figure 11: Magnetic coupling factor k for a fixed antenna setup

To summarise we notice, that the coupling factor k is simply a geometrical parameter, not influenced by any electrical values.

2.5 Quality factor, phase shift and bandwidth

As well as the coupling factor we just discussed before, the quality factor Q of the reader antenna is a key parameter to a good RFID system performance. The selection of an appropriate quality factor Q has influence on:

- the reading distance,
- the antenna damping and
- the reception bandwidth.

Firstly, the quality factor can be calculated by:

$$Q = \frac{f_0}{\Delta f} \quad [1] \quad (16)$$

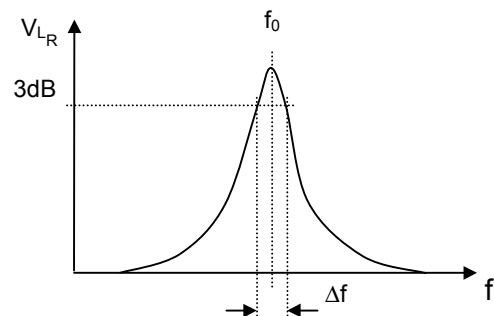

Figure 12: Series resonance curve

Secondly, the quality factor Q can also be expressed by circuit parameters of the reader antenna setup.

$$Q_R = \frac{2 \cdot \pi \cdot f_0 \cdot L_R}{R_{L_R}} \quad [1] \quad (17)$$

Furthermore the resonance voltage at the coil is:

$$V_{L_R} = Q \cdot \frac{2 \cdot V_{DD}}{\pi} \quad [V] \quad (18)$$

For this reason we can measure 50V ... 100V at the reader antenna, depending on what quality factor Q and supply voltage V_{DD} we choose.

The following step will be, to optimise the transmission parameters of the „transformer system“. To design the as big as necessary, not as possible, we proceed as followed:

$$V_{L_T} = V_{L_R} \cdot Q_T \cdot k \cdot \sqrt{\frac{L_T}{L_R}} \cdot \cos(\varphi) \quad [V] \quad (19)$$

The minimum voltage V_T desired by the transponder can be found in the datasheet of the chosen transponder. But it is usually limited by clamping diodes to a value of $V_{Tmax} = 18V_{pp}$.

Now as we have two independent resonant circuits, running as a series resonance (reader) and a parallel resonance (transponder) it can occur, that they are not exactly tuned to the desired frequency. Reasons may mostly be:

- Temperature effects and
- Component (L, R, C) tolerances.

To imagine the influence of some percents of drift the following formula was visualised [B2]:

$$\varphi = \left[\arctan Q_R \cdot \left(\Omega - \frac{1}{\Omega} \right) \right] \cdot \frac{180}{\pi} \quad [^\circ] \quad (20)$$

$$\Omega = \frac{f_T}{f_R} \quad [-]$$

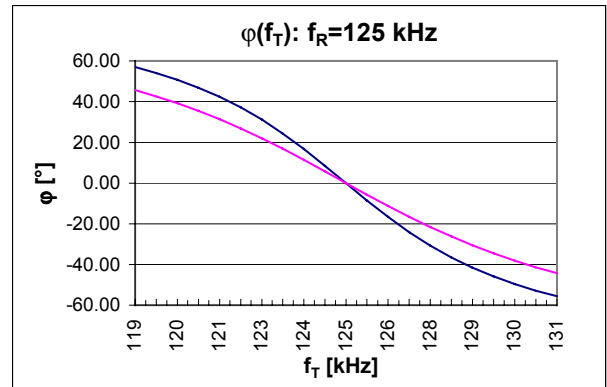

Figure 13: Phase shift φ between two resonant circuits

If φ becomes 90° the transmitted transponder signal is being cancelled. No signal can be detected therefore. To avoid such effects, precise components, especially capacitors should be used. Furthermore the quality factor Q should be held as low as possible, as you can see in (20).

Finally, we want to have a look at the reception bandwidth of the reader [B5].

The transponder mostly receives its commands by a AM signal generated by the reader. Often, the modulation index of the AM is 1 or 100%. Considering a communication data rate of 2kbit/s generates the typical sidebands of $125kHz \pm 2kHz$.

The selection of an appropriate quality factor, as discussed before in this chapter and the limitation of the communication bandwidth can be visualised in the following figure.

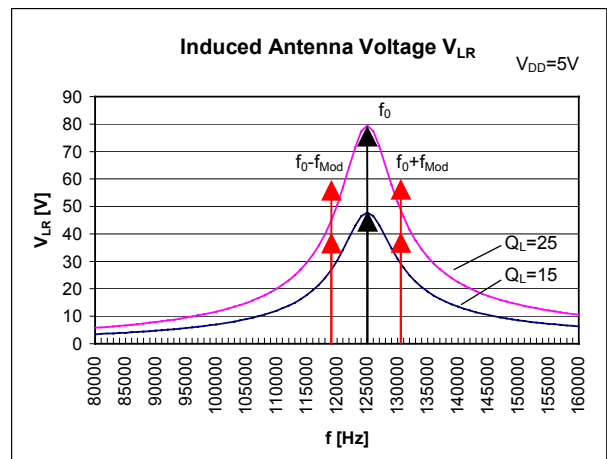

Figure 14: Induced antenna voltage

Figure 14 shows the induced voltage on the reader antenna for two different quality factors. Rising Q is mostly limited by component and temperature tolerances. Thus, tuning becomes more critical with a higher Q.

3 Antenna design

This chapter describes how to design your reader or transponder antenna. Antenna coils can be configured in many different ways. It mostly depends on the purpose of the application and the constraints given by the mechanical setup (i.e. car immobiliser or handheld reader). Usually thin wire is used for antennas at 125kHz, with about 40 turns and more. For 13.56MHz often printed circuit boards or thin film technology is used to place one to about seven turns. At frequencies in the microwave range, such as 2.45GHz, antennas are commonly designed as dipoles, according to the corresponding wavelength.

Thus, although this is not quite an orthodox method, it has some practicability. Of course there are more appropriate ways to setup the antenna and the analog frontend in RFID applications. Therefore the following guidelines will help to design your system more efficiently.

As we have seen in the precedent chapters, there are several parameters to take in account, while designing an RFID application. We have to find a compromise between e.g. the quality factor Q_R at the reader and the induced voltage at the transponder. Designing an RFID application is a recursive procedure. Once the resonance frequency is fixed, the following diagram can be taken as a guideline. Nevertheless it is an iterative procedure:

Step	Action	param. given	param. to calculate
1	determine a transponder (e.g. EM4001). ¹⁾	$V_{Tmin}, \gamma_T, L_T, N_T, Q_T$	R_T
2	fix the mechanical parameters.	r_R	H_{min}, B_{min}
3	determine the inductivity and the quality factor of the reader ant.	L_R, Q_R	R_{L_R}, N_R
4a	either you fix the max. reader current.	I_R	x, R_R
4b	or you try to maximise the distance. remember the formula (4).	x	I_R, R_R

¹⁾ Usually the transponder is a complete set of the chip and the antenna and resonance capacitor. Therefore mechanical and electrical parameters, such as the antenna diameter, the quality factor etc. are given.

Table 4: Design flow procedure

3.1 General resonant circuit parameters

As mentioned earlier, RFID data and energy transmission is based on magnetically coupled resonance circuits.

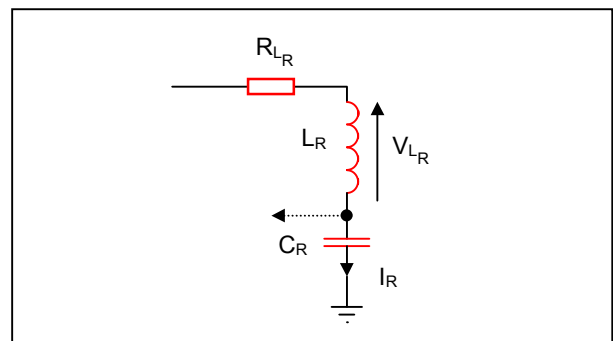
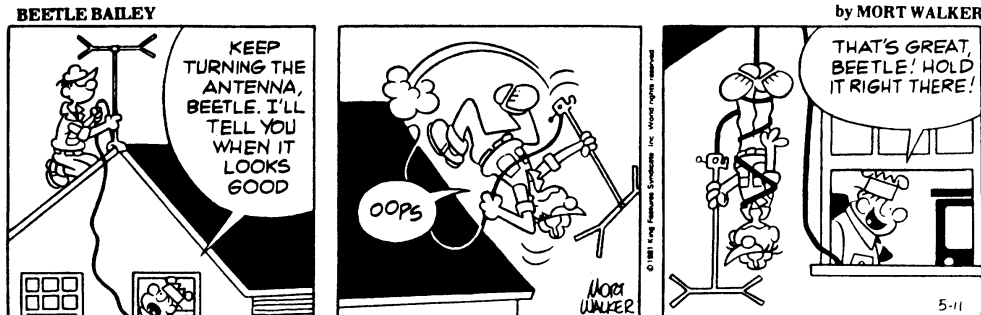

Figure 15: Series resonance circuit at the reader side

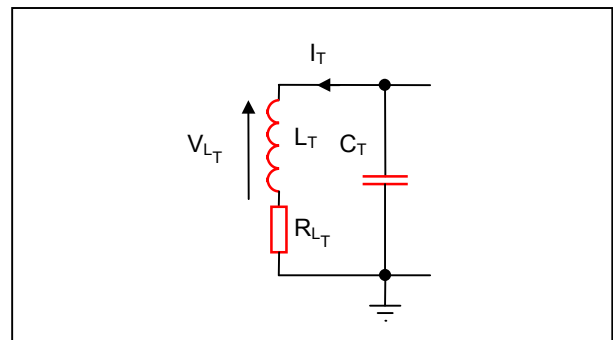

Figure 16: Parallel resonance circuit at the transponder side

Mathematically can be shown, that in a resonance circuit we have

$$\omega_0^2 \cdot L \cdot C = 1 \quad [1] \quad (21)$$

and therefore the resonance frequency will be:

$$f_0 = \frac{1}{2 \cdot \pi \cdot \sqrt{L \cdot C}} \quad [Hz = s^{-1}] \quad (22)$$

To become more specific on each resonance circuit, basic formulas for each case are shown below [2]:

Series resonance

$$R_S = \frac{V_S}{I_S} \quad [\Omega] \quad (23)$$

$$Z_S = \sqrt{\frac{L_S}{C_S}} = \omega_S \cdot L_S \quad [\Omega] \quad (24)$$

$$Q_S = \frac{Z_S}{R_S} = \frac{1}{R_S} \cdot \sqrt{\frac{L_S}{C_S}} \quad [1] \quad (25)$$

Parallel resonance

$$G_P = \frac{I_P}{V_P} \quad [S = \frac{A}{V}] \quad (26)$$

$$Y_P = \sqrt{\frac{C_P}{L_P}} = \omega_P \cdot C_P \quad [S] \quad (27)$$

$$Q_P = \frac{Y_P}{G_P} = \frac{1}{G_P} \cdot \sqrt{\frac{C_P}{L_P}} \quad [1] \quad (28)$$

While Q_S is the multiplying factor for the generator voltage, Q_P is the factor for the current.

Here we remember (14), (18) and combining them with (28), hence we get the induced voltage at the transponder coil:

$$V_T = Q_T \cdot N_T \cdot B \cdot A_T \cdot \omega_T \cdot \cos(\theta) \quad [V] \quad (29)$$

θ is still the angle between both antennas, according to Figure 10, and $\cos(\theta) = 1$ if they are in parallel.

Using design flow procedure from Table 4, we can now calculate a complete system.

Example 3-1:

For a given transponder coil, we want to calculate the minimum magnetic flux density B_{\min} . Considering the following transponder parameters as given:

$f_0 =$	125kHz	frequency
$L_T =$	9.5mH	inductivity
$R_T =$	480 Ω	coil resistance
$N_T =$	433	number of turns
$d_T =$	27mm	coil diameter, circular shaped
$V_{T\min} =$	3.5V _{PP} (e.g. EM4001)	minimum voltage at transponder
$\theta =$	0°	angle between antennas

$$B_{\min} = \frac{V_{T\text{PP}}}{Q_T \cdot N_T \cdot A_T \cdot \omega_T \cdot \cos(\theta)} \quad [T] \quad (30)$$

$$Q_T = \frac{\omega_T \cdot L_T}{R_T} = \frac{2\pi \cdot 125\text{kHz} \cdot 9.5\text{mH}}{480\Omega} = 15.54$$

$$A_T = \frac{d_T^2 \cdot \pi}{4} = \frac{(27\text{mm})^2 \cdot \pi}{4} = 0.57 \cdot 10^{-3} \text{m}^2$$

$$B_{\min} = \frac{3.5V_{\text{PP}}}{15.5 \cdot 433 \cdot 0.57 \cdot 10^{-3} \text{m}^2 \cdot 2\pi \cdot 125\text{kHz} \cdot \cos(0)} = 1.17 \frac{\mu\text{V}_{\text{PP}}}{\text{m}^2}$$

3.2 Antenna parameters

Supposing the mechanical dimensions for the reader antenna in an application are given. The required B-field from Example 3-1 can be taken for that specific transponder. There are two parameters of interest, depending on the application requirements, either the current I_R or the distance x .

Combining (5) and (30) result in:

$$I_R(x) = \frac{2B_{\min} \cdot (r_R^2 + x^2)^{3/2}}{\mu_0 \cdot N_R \cdot r_R^2} \quad [A] \quad (31)$$

$$x(I_R) = \sqrt{\left(\frac{I_R \cdot \mu_0 \cdot N_R \cdot r_R^2}{2B_{\min}} \right)^{2/3} - r_R^2} \quad [m] \quad (32)$$

Example 3-2:

Using the values from Example 3-1, the necessary parameters for the reader can be calculated now:

$f_0 =$	125kHz	frequency
$L_T =$	9.5mH	inductivity
$R_T =$	480Ω	coil resistance
$N_T =$	433	number of turns
$d_T =$	27mm	coil diameter, circular shaped
$V_{Tmin} =$	3.5V _{PP} (e.g. EM4001)	minimum voltage at transponder
$\theta =$	0°	angle between antennas
$V_{DD} =$	5V	reader supply voltage (DC)
$r_R =$	3cm	reader antenna radius
$r_0 =$	0.2mm	reader antenna wire (initial value)
$L_R =$	400uH	reader antenna inductivity
$I_{Rp} =$	100mA	reader antenna current amplitude
$Q_R =$	15	reader antenna quality factor

The number of turns of the reader coil can be calculated:

$$N_R = \left(\frac{400\mu H}{4\pi \cdot 10^{-7} \cdot 30 \cdot 10^{-3} \cdot m \cdot \ln\left(\frac{30 \cdot 10^{-3}}{0.1 \cdot 10^{-3}}\right)} \right)^{1/1.9} = 52.6$$

We take $N_R=53$.

$$V_{LR} = \frac{2 \cdot Q_R \cdot V_{DD}}{\pi} = \frac{2 \cdot 15 \cdot 5V}{\pi} = 47.7V$$

The coupling factor $k(x)$ is either valuated by (15), or it can be measured in-system as:

$$k(x) = \frac{V_T}{V_R} \cdot \sqrt{\frac{L_R}{L_T}} \quad [1] \quad (33)$$

As the coupling factor We consider both resonance circuits tuned to the exact frequency, then the signal phase between both circuits will be $\varphi=0$ and the voltage at the transponder according to (33) and taking $k=0.1$:

$$V_T = 5V \cdot \frac{4}{\pi} \cdot 15 \cdot 0.1 \cdot \sqrt{\frac{9.5mH}{400\mu H}} = 46.6V$$

Finally, the total resistance at the reader R_R is being the sum of all partial resistances, such as:

- driver resistance
- contact resistance at the antenna
- copper resistance

Therefore the maximum current can be drawn, if [4]:

$$I_R(x) = \frac{V_{DD}}{R_R + \omega_R \cdot L_R \cdot k^2(x)} \quad [A] \quad (34)$$

Calculating an RFID system is quite an iterative process. Once You have calculated a system, build it up, measure and compare these values with the calculation results.

Mostly, You will spend a nice piece of time tuning your antenna setup to assure, it will not only run on your prototype but also in the production series. Practical tips can be found in the next chapter.

3.3 Antenna fine tuning

Having built the RFID reader, you will have to tune the system due to component tolerances, temperature effects etc. A very efficient way to tune the resonance circuit, even while the system is running is, by displaying the resonance voltage on a simple oscilloscope. As shown in the following figure, resonance is reached, if the leap on the sinewave is exactly at the maximum/minimum. The lower trace shows V_{Drv} , the output stage of the reader:

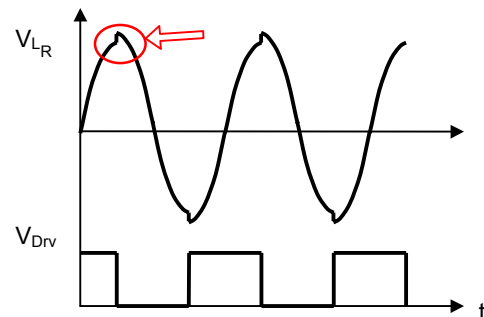

Figure 17: Tuning the resonance circuit

The tuning can be done by either changing the capacitor or the inductivity.

Another possibility of circuit tuning offers a comfortable spectrum analyser. Thus, there is no need to tune the system while its running. It suits well for series production tests.



4 Data Coding/Encoding

Transmitter (Tag)

The tag is responsible for 'encoding' i.e. inserting clocks into the datastream according to a select coding scheme.

Receiver (Reader)

Receiver is responsible for 'decoding' i.e. separating clocks and data from the incoming embedded datastream.

4.1 Non-return to Zero Modulation (NRZ)

Description

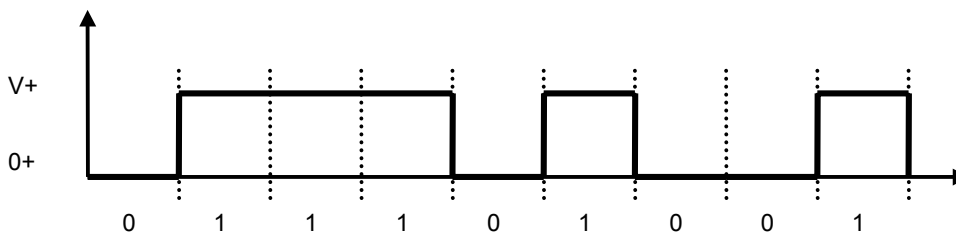

Low level = 0V

High level = +V

For each bit, there are n clocks (data rate).

- Requires time co-ordination: Long strings of '0' and '1' do not produce any transitions which may create problems in error detection and recovery.
- High DC level (average of $\frac{1}{2}$ Volts).

4.2 Return to Zero Modulation (RZ)

Description

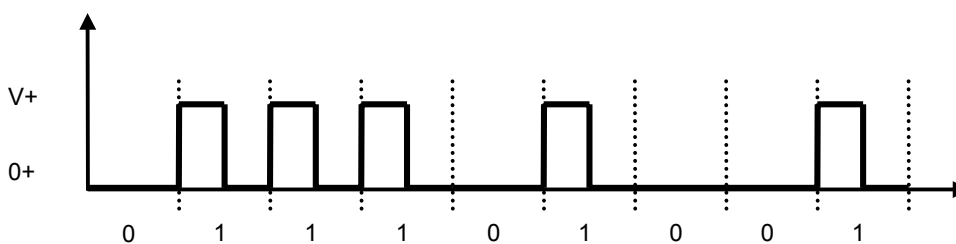

Low level = 0V

High level = +V during the first half of the bit and 0 during the second half.

- DC average is only $\frac{1}{4}$ Volts.
- Requires time co-ordination



4.3 Manchester Coding

This code is self-clocking

- There is a *transition in the middle* of each bit period
- A *1 to 0 transition* represents a '0' bit
- A *0 to 1 transition* represents a '1' bit

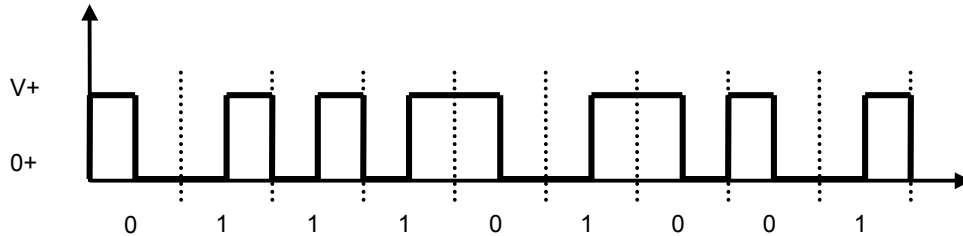

The mid-bit transition is used as clock as well as data.

- The residual DC value is eliminated by having both polarities for every bit
- The bandwidth required could be twice the bit rate (Efficiency of this code can be as low as 50%)

4.3.1 Differential Manchester Coding

This code is self-clocking

- There is a *transition in the middle* of each bit period
- A *transition at the start* of the bit period represents a '0' bit

No *transition at the start* of the bit period represents a '1' bit

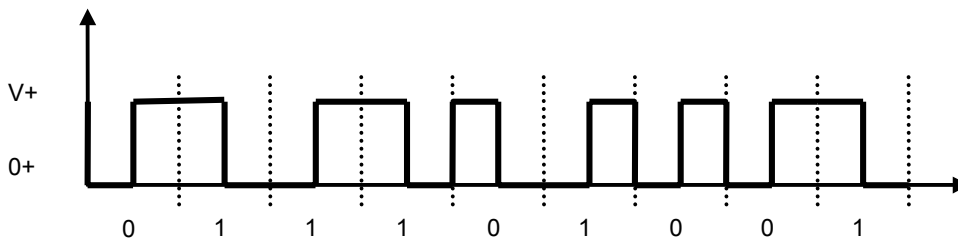

The mid-bit transition is used only to provide clocking.



4.4 Biphase Coding

Biphased data streams have generally a signal change in the middle of each bit, independent of the value. Therefore the signal does not necessarily return to zero.

The advantages of the biphase method are:

- **Synchronisation:** Since there is a predictable transition for each bit, the receiver can synchronise on this edge. These codes are also known as *self-clocking*.
- **Error immunity:** To cause an error, the noise must invert both, the signal before and after the transition.

4.4.1 Differential Biphase Coding

- There is a *transition at the start* of each bit period
- A '0' bit has generally a transition in the middle of the bit period (pos. or neg.)
- A '1' has no transition in the middle of the bit period

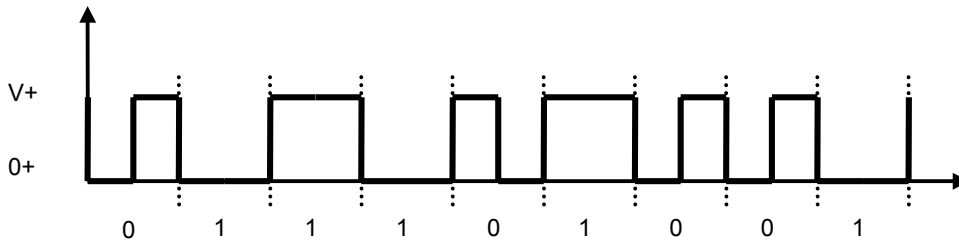

4.5 Miller Coding

- There is a transition in the middle of a bit period, if it is a bit '1'
- There is no transition at the start of the bit period, if the bit is '0', followed by a '1' bit
- There is a transition at the start of the bit period, if the bit '0' is followed by a '0' bit

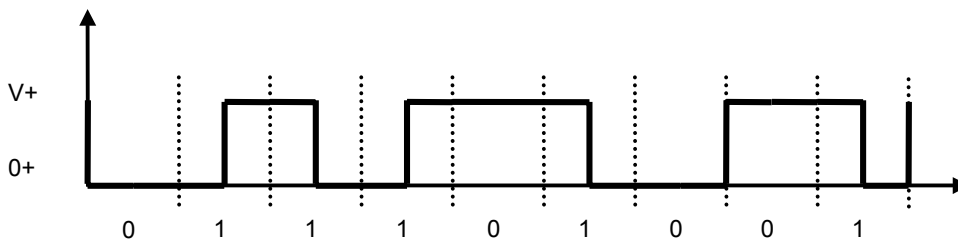

This code is very efficient, regarding the desired bandwidth (half of the desired bandwidth of Manchester Coding).

4.6 Phase Shift Keying

Phaseshift keyed data is only decodable with angle sensitive demodulators. The data information can be found in the phase of the signal. AM demodulators will show no results.

- A bit '1' has a signal phase of π or 180°
- A bit '0' has a signal phase of 0°

The interpretation of the digital value can as well be interpreted inverse ('1' $\rightarrow \pi$, '0' $\rightarrow 180^\circ$).

The conventional understanding of PSK is shown in the following figure, where the carrier is modulated by the transmitter (reader).

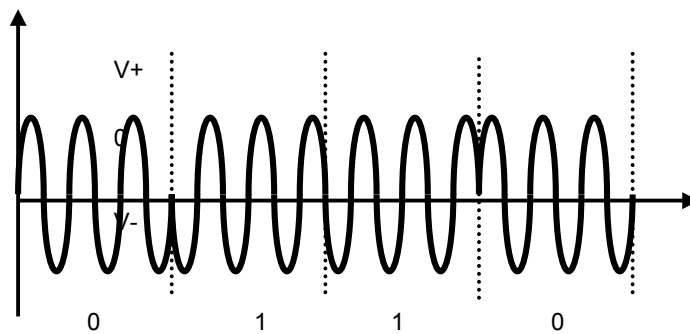

PSK modulation is also possible if the carrier is quasi-amplitude-modulated by the transponder as principally shown in the following figure.

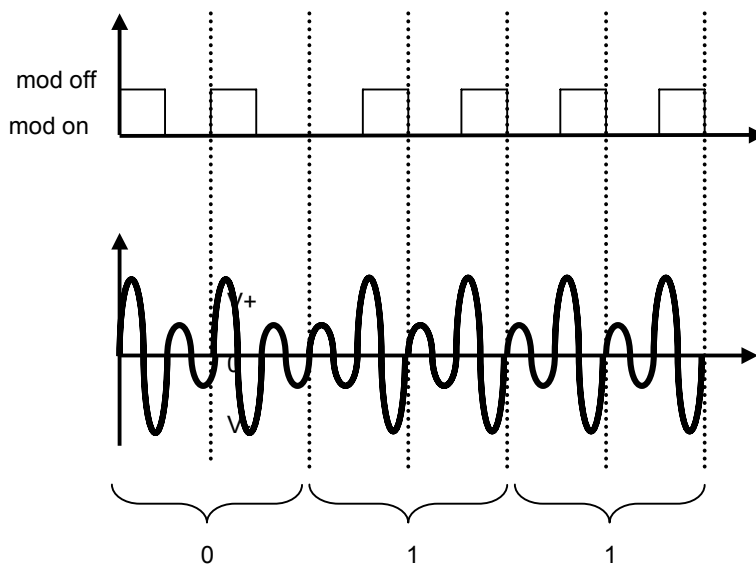

The above example shows a PSK modulation with two periods per bit of data information. The upper trace is the control of the transponder modulator.



5 Bibliography

- [B1] P. Grivet,
The Physics of Transmission Lines at High and Very High Frequencies,
Academic Press, London, 1970.
- [B2] Karl Küpfmüller, Gerhard Kohn,
Theoretische Elektrotechnik und Elektronik,
Springer Verlag, Berlin, 14th edition, 1993.
- [B3] Klaus Finkenzeller,
RFID-Handbuch,
Hanser Verlag, München, 1st edition, 1998.
- [B4] Thierry Roz, Vincent Fuentes,
Using low power transponders and tags for RFID applications,
6th Wireless Symposium – February 9-12th, 1998, Santa Clara, CA, USA
EM Microelectronic-Marín SA, Marín.
- [B5] Eberhard Herter, Wolfgang Lörcher,
Nachrichtentechnik,
Hanser Verlag, München, 7th edition, 1994.
- [B6] W. Buesser, J. Rudin, N. Nandra, P. Goguillot, T. Roz, V. Fuentes,
A Contactless Read / Write Transponder Using Low Power EEPROM Techniques,
ESSCIRC 96 – September 17-19th, 1996, Neuchâtel, Switzerland,
EM Microelectronic-Marín SA, Marín.

6 Glossary

Anticollision	Ability of an RFID system to avoid data collision of multiple transponders in the electromagnetic field of a single reader.
Keying	Keying means turning a transmitter on and off.
Reader	device or system to read the identification code of a Read-Only transponder or to program and read a Read/Write transponder.
RFID	Radio Frequency Identification.
Tag	Packed, embedded transponder. Also referred to as data carrier, label, RFID-card, identifier.
Transponder	Subassembly consisting at least of an antenna and a semiconductor, containing the desired functionality. Further components, such as capacitors, diodes etc. may be required to complete the resonant circuit or provide other elements like voltage limitations etc.

θ	deg.	Angle between the reader and the transponder antenna.
μ_r	-	Permeability of ferromagnetic materials.
A	m ²	Antenna surface.
B	T	Magnetic flux density.
C_R	F	Capacity of the reader resonance circuit.
C_T	F	Capacity of the transponder resonance circuit.
f₀	Hz	Resonance frequency.
GND	V	Power supply ground.
H	A/m	Electromagnetic field strength
I_R	A	Reader antenna current.
I_T	A	Transponder antenna current.
k	-	Coupling factor of between two antennas.
L_R	H	Reader antenna inductivity.
L_T	H	Transponder antenna inductivity.
M	H	Mutual inductivity.
N_R	-	Number of windings of reader antenna.
N_T	-	Number of windings of transponder antenna.
Q_R, Q_S	-	Quality factor of the reader antenna (series resonance).
Q_T, Q_P	-	Quality factor of the transponder antenna (parallel resonance).
r₀	m	Antenna wire radius.
R_{L_R}	Ω	Copper resistance of the reader antenna inductivity.
R_{L_T}	Ω	Copper resistance of the transponder antenna inductivity.
r_R	m	Reader antenna radius.
V_{DD}	V	Power supply voltage at the antenna driver.
V_R	V	Voltage at the reader resonance circuit.
V_T	V	Voltage at the transponder resonance circuit.
x	m	Distance between reader and transponder antenna.
μ_0		Magnetic field constant is $\mu_0 = 4\pi \cdot 10^{-7}$ A/Vs.
c		The speed of light in vacuum is $c = 299.79$ km/s.



AppNote 411

7 Appendix

7.1 Institutes

[A1] **International Telecommunication Union (ITU)**

Place des Nations
CH-1211 Geneva 20
Switzerland
Tel.: +41 22 730 51 11
Fax: +41 22 733 72 56
e-mail: itumail@itu.int
homepage: <http://www.iut.int>

[A2] **International Organization for Standardization (ISO)**

1, rue de Varembe
Case postale 56
CH-1211 Genève 20
Switzerland
Tel.: + 41 22 749 01 11
Fax: + 41 22 733 34 30
e-mail: central@iso.ch
homepage: <http://www.iso.ch>

[A3] **European Telecommunications Standards Institute (ETSI)**

ETSI Publication Office
650 Route Des Lucioles
F-06921 Sophia Antipolis Cedex
France
Tel.: +33 (0)4 92 94 49 00
Fax: +33 (0)4 92 96 03 07
e-mail: helpdesk@etsi.fr
homepage: <http://www.etsi.org>

[A4] **Federal Communications Commission (FCC)**

445 12th St. SW
Washington DC 20554
USA
Tel.: (202) 418-0190
e-mail: fccinfo@fcc.gov
homepage: <http://www.fcc.gov>

7.2 Trade fairs:

[A5] **SCANTECH Europe**

Trade Fare for Automatic Data Capture and
Mobile Computing
homepage: <http://www.scantech-europe.com>

7.3 Copper Wire List

Copper wire for diameters 0.020 to 0.530mm¹⁾:

diameter d [mm]	surface A [mm ²]	equiv. res. δ [Ω /m]
0.020 ²⁾	0.000314	54.88
0.025	0.000491	35.12
0.032	0.000804	21.44
0.036	0.001018	16.94
0.040	0.001257	13.72
0.045	0.001590	10.84
0.050	0.001964	8.781
0.056	0.002463	7.000
0.063	0.003117	5.531
0.071	0.003959	4.355
0.080	0.005027	3.430
0.090	0.006362	2.710
0.100	0.007854	2.195
0.112	0.009852	1.750
0.125	0.01227	1.405
0.132	0.01368	1.260
0.140	0.01539	1.120
0.150	0.01767	0.9756
0.160	0.02011	0.8575
0.170	0.02270	0.7596
0.180	0.02545	0.6775
0.190	0.02835	0.6081
0.200	0.03142	0.5488
0.212	0.03530	0.4884
0.224	0.03941	0.4375
0.236	0.04374	0.3941
0.250	0.04909	0.3512
0.265	0.05515	0.3126
0.280	0.06158	0.2800
0.300	0.07069	0.2439
0.315	0.07793	0.2212
0.335	0.08814	0.1956
0.355	0.09898	0.1742
0.375	0.1104	0.1561
0.400	0.1257	0.1372
0.425	0.1419	0.1215
0.450	0.1590	0.1084
0.475	0.1772	0.09730
0.500	0.1964	0.08781
0.530	0.2206	0.07815

¹⁾ by Von Roll-Isola Cable and Wire, Breitenbach, Switzerland.

²⁾ diameters in bold face meet CEI 182-1 recommendation.



Notes

EM Microelectronic-Marin SA cannot assume responsibility for use of any circuitry described other than circuitry entirely embodied in an EM Microelectronic-Marin SA product. EM Microelectronic-Marin SA reserves the right to change the circuitry and specifications without notice at any time. You are strongly urged to ensure that the information given has not been superseded by a more up-to-date version.

© EM Microelectronic-Marin SA, 09/02, Rev. D